



SERVERS

# Multi Switch ATS



**16A**  
Single-phase

## Highlights

- Load protection
- Versatility of use
- Only 1U

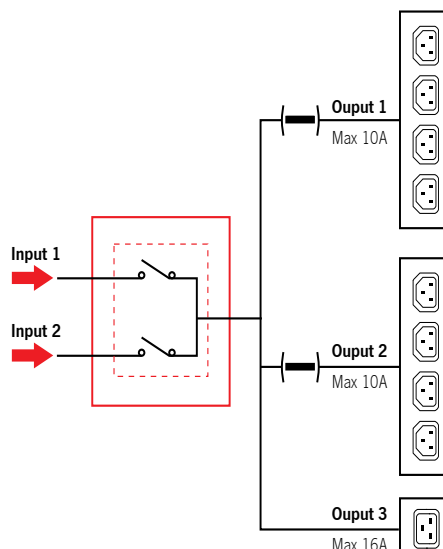

Multi-SWITCH ATS provides extreme power supply continuity to the installation. Its operating principle ensures higher reliability than a single UPS or one with a bypass.

### Operating principle

Multi Switch ATS provides direct distribution of eight 10A IEC utilities or one 16A IEC utility in a system with two power supply lines of any type (two mains inputs, or two UPS).

Multi Switch ATS is able to connect to either of the two power supply lines, while also monitoring absorption.

### Protection against load faults

In case one of the loads fails (e.g. short

circuit) the Multi Switch ATS disconnects the group of sockets where the load itself is connected, thus preventing other loads from being switched off (e.g. in case of poor protection selectivity) .

### Protection against power supply faults

In the event one of the two power sources does not fall not within the tolerances, Multi-Switch ATS will switch the other loads to the second power source (this occurs instantaneously if the two sources are in phase).

### Features

- Full utilities protection against mains and load failures
- Versatility of use: Multi Switch ATS can be powered with 2 different power supplies (2 UPS devices even of different sizes/types)
- Wiring on 19" cabinet
- Mimic panel

- Can be connected to PowerNetGuard supervision software
- No signal connection between the Multi Switch ATS and the power sources or utilities is necessary.
- Compatible with Powershield<sup>3</sup> software
- Slot for communication boards

### particulars

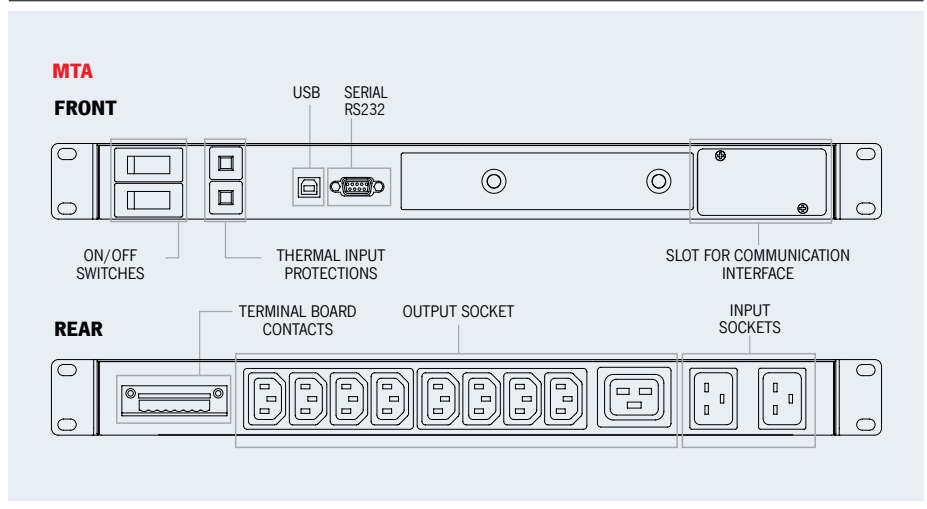

MODELS	MTA
CORRENTE	16A
INPUT	
Nominal voltage	180 - 276 Vac
Nominal frequency	50 or 60 Hz
Max load for every input (A)	16
INPUT SOCKETS	2 IEC-320 C20 (16A)
OUTPUT	
Nominal voltage	choice between the two input power sources
Max load for every output (A)	10A su IEC-320 C13 - 16A su IEC-320 C19
Output socket	4+4 IEC-320 C13 (10A) + 1 IEC-320 C19 (16A)
INFO FOR INSTALLATION	
Weight (kg)	6
Dimensions (hwd) (mm)	1U x 19" x 330
Ambient temperature	0°C / +40°C
Relative humidity	< 95% non-condensing
Protection devices	Overcurrent - overvoltage - undervoltage - thermal - protection against energy back-feed
Max altitude	3000 m
Max altitude (in storage conditions)	6000 m; 45 °C
Communication	DB con RS232, USB, slot for communications interface, porta a contatti a relé
Colour	Dark grey RAL 5004
Protection level	IP20
Noise level	< 35 dBA a 1 m