



SERVERS

# Master Switch



## STS

## Highlights

- High reliability
- “Hot Replacement” function
- 3- or 4-pole version
- Advanced communication



Installing a MASTER SWITCH static transfer switch provides additional resilience and protection from the disruption that can be caused by the failure of a single power source. The result is the absolute protection of industrial utilities and critical information technology against power supply and load faults.

### **Operating principle**

MASTER SWITCH guarantees a source of redundant power, allowing the load to be switched between to alternative and independent power sources. Switching can be automatic (when a supply source falls outside of acceptable tolerances) or manually done by an operator from the front panel or remotely.

## Protection against power supply faults

In the event that one of the two power sources does not fall within accepted tolerance values, MASTER SWITCH will transfer the other loads over to the second power source (this happens instantly if the two sources are in phase).

## Protection against environmental disturbances

### Load overloads and faults

In the event of an overload, the user can decide the level of intervention of the internal protections in order to block the supply of energy. In the extreme case a downstream short circuit, MASTER SWITCH disconnects the load, in order to prevent jeopardising the operation of other loads (e.g.. in case of poor protection selectivity).

## Total microprocessor control

Microprocessor control logic ensures:

- Fast and safe switching between power sources
- Monitoring of all parameters via LCD display
- Constant control of the SCRs
- Advanced remote diagnostics (RS232 and TCP/IP)

## Redundant Design

Power is supplied to the internal logic by two, separate supply circuits that are fully independent and that can be replaced in "hot replacement" mode without causing power supply interruptions to the load. In the event that the power supplied by both sources fails, full system operation is guaranteed by the **Power Supply Backup** function that provides auxiliary power supply to the circuit through an external, independent power source. MASTER SWITCH is equipped with dual redundant ventilation defined as: "fan

**redundancy plus**". Thanks to this feature, and in the unlikely event that two fans fail at the same time, those remaining would still be able to dissipate the heat generated at rated load and with an ambient temperature up to 40° C. The fans can be replaced in "hot replacement" mode, ensuring continuity during the intervention.

## High protection

In the event of an output short circuit, MASTER SWITCH will block the transfer between the two power sources eliminating the risk of propagating the short circuit and its effects on the other loads.

A backfeed control circuit ensures the automatic intervention of protection devices when a return of energy to one of the two MASTER SWITCH inputs is detected.

## Accessibility

The layout of the moving components and parts is designed to ensure easy frontal access:

- power cable connections that are easily accessed with entry from below
- boards housed in a dedicated area for rapid diagnosis / replacement
- all parts subject to controls, maintenance and/or replacement.

## Advanced communication

Master Switch provides information, measurements, statuses, and alarms via the LCD display.

The STS is compatible with Powershield<sup>3</sup> supervision and shutdown software for Windows operating systems 7, 2008, Vista, 2003, XP, Linux, Mac OS X, and Sun Solaris.

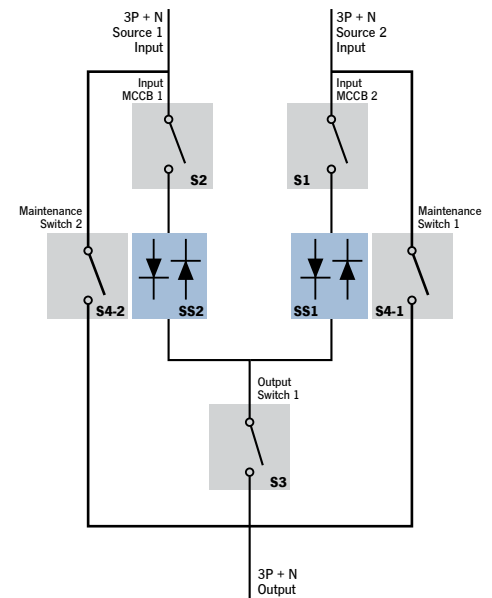

## dimensions (mm)



LED	FUNCTION
L1	S1 Priority Source
L2	S2 Priority Source
L3	S1 Present
L4	S2 Present
L5	Static transfer switch SS1 closed
L6	Static transfer switch SS2 closed
L7	Alarm indicator
L8	Output selector ON/OFF
5 function keys and LCD operation	

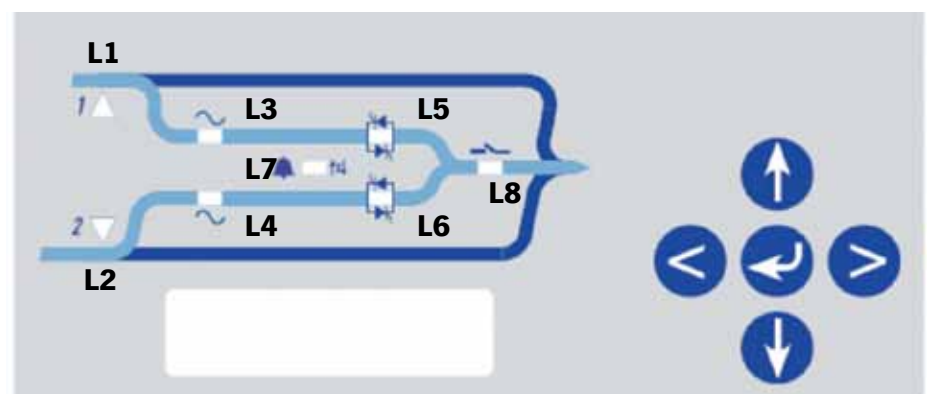

MASTER SWITCH in  
**REDUNDANT mode**

The secondary source [AS], although highly reliable, only powers the load power in the event of a failure with the priority source [PS], ensuring maximum redundancy and power quality to the loads.

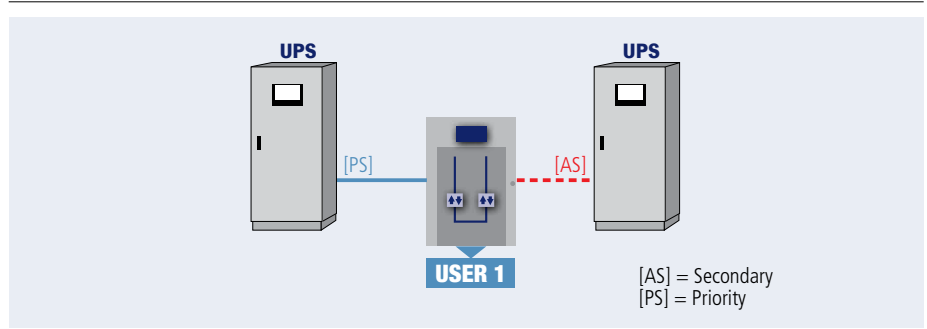

MASTER SWITCH in  
**CROSS FEEDING Mode**

The two sources power critical loads using MASTER SWITCHES configured to selected one of the two power sources as the priority source (PS). In case of a failure in one of two sources, the other will be able to supply power to all the loads connected to the system).

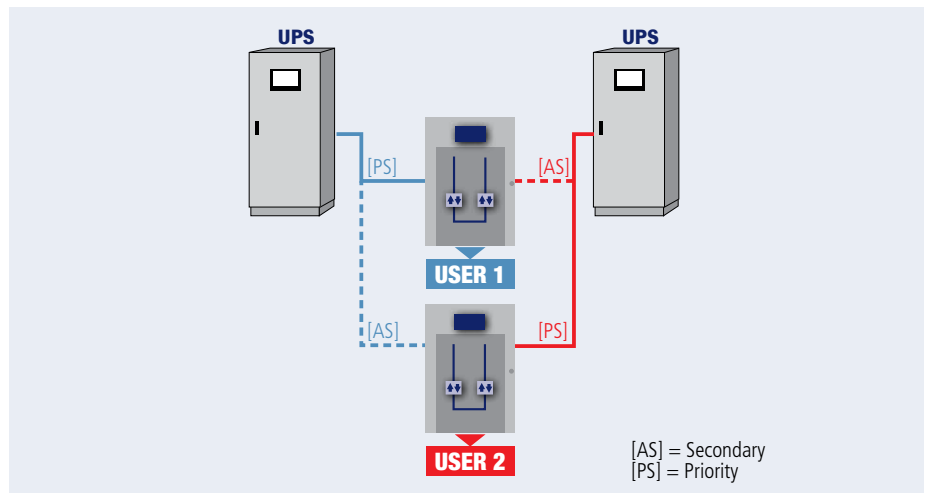

MASTER SWITCH in  
**BACK-UP mode**

MASTER SWITCHES power utilities via the priority energy source [PS]; the secondary energy source [AS] is made up of independent, separate power sources and to make up for any faults in the priority power source. [PS]

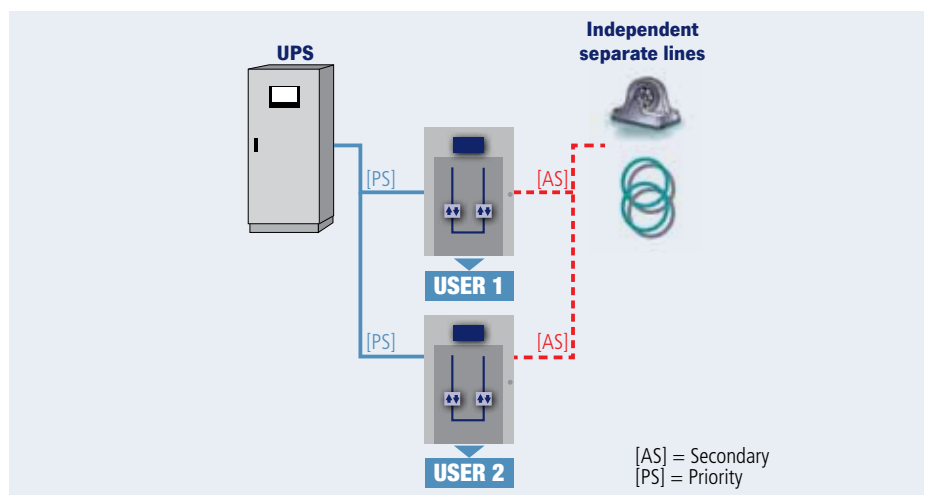

**DYNAMIC DUAL BUS CONFIGURATION**

The Riello UPS solution guarantees maximum reliability and ensures continuity of power supply in all operating conditions thanks to the UGS option that keeps the two systems, A and B, perfectly synchronised.

The flexibility of the UGS system ensures synchronism between the sources even when one of the two systems is not a Riello UPS model but rather is made by another manufacturer or when the input sources are not UPSs.

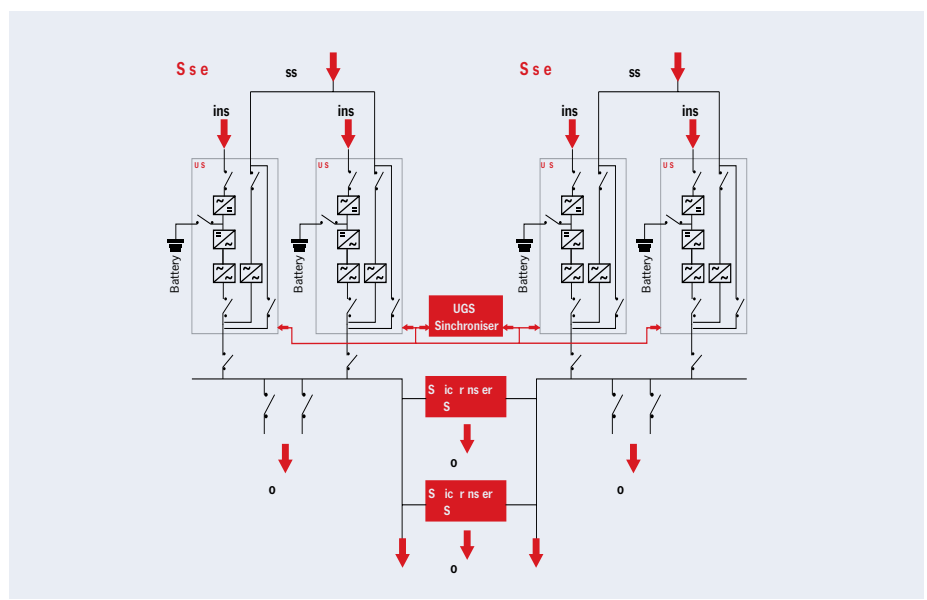

MODELS	MTS 100	MTS 150	MTS 200	MTS 250	MTS 300	MTS 400	MTS 600
<b>RATED CURRENT (A)</b>	<b>100</b>	<b>150</b>	<b>200</b>	<b>250</b>	<b>300</b>	<b>400</b>	<b>600</b>
<b>INPUT</b>							
<b>Nominal voltage - sources S1/S2</b>	380 - 400 - 415 Vac three-phase with neutral						
<b>Input voltage tolerance</b>	180÷264 Vac (selectable)						
<b>Switched input phases</b>	3+N (4-pole) - 3 (3-pole)						
<b>Nominal frequency</b>	50 or 60 Hz						
<b>Input frequency tolerance range</b>	+/-10% (selectable)						
<b>Distribution compatibility</b>	IT, TT, TNS, TNC						
<b>OPERATING FEATURES</b>							
<b>Transfer type</b>	"Break Before Make" (no overlapping sources)						
<b>Available transfer methods</b>	Automatic / Manual / Remote						
<b>Transfer time for source failure</b>	< 4 msec (S1/S2 synchronised) 10 msec (S1/S2 NON synchronised)						
<b>ENVIRONMENTAL</b>							
<b>Efficiency at full load (%)</b>	> 99%						
<b>Noise level at 1 m from front (dBA) (from 0 to full load) - (dBA)</b>	55	55	55	55	55	55	57
<b>Storage temperature</b>	-10°C up to +50°C						
<b>Ambient temperature</b>	0°C - 40°C						
<b>Relative humidity</b>	95% non-condensing						
<b>Max installation height</b>	1000 m at rated power (-1% power for every 100 m above 1000 m) - Max 4000 m						
<b>Reference Standards</b>	EN 62310-1 (safety) EN 62310-2 (electro-magnetic compatibility)						
<b>INFO FOR INSTALLATION</b>							
<b>Weight (kg)</b>	155	175	205	210	220	240	375
<b>Dimensions (hwd) (mm)</b>	1500 x 685 x 530		1770 x 685 x 580				1900 x 950 x 730
<b>Colour</b>	RAL 7016						
<b>Protection level</b>	IP 20						