



LOCAL AREA NETWORKS (LAN)



SERVERS



DATA CENTRES



TELECOMMUNICATIONS DEVICES



E-BUSINESS (Servers Farms, ISP/ASP/POP)



INDUSTRIAL PROCESSES



INDUSTRIAL PLCS



ELECTRO-MEDICAL DEVICES



EMERGENCY DEVICES (Lights/Alarms)

Master MPS



10-800 kVA
Three-phase/Three-phase

10-100 kVA
Three-phase/Single-phase

Highlights

- Efficiency Control System (ECS)
- Galvanic Separation
- High overload capacity
- LCD Display
- Numerous parallel solutions



Absolute protection

Master MPS series UPS devices ensure maximum protection and power quality for any type of load, especially for mission critical applications, security systems and electro-medical equipment, industrial processes and telecommunications. Master Plus is an on-line double conversion UPS (class VFI SS

111 in accordance with IEC EN 62040-3) with a transformer isolated inverter.

The Master Plus range includes three-phase input and single-phase output versions from 10 to 100kVA, and three-phase input and output versions 10 to 800kVA. The three-phase versions are available from 10 to 200 kVA with a 6-pulse thyristor rectifier and, for some

powers, with 12-pulses.

From 100kVA to 500kVA, the HP versions with IGBT rectifiers offer the best solution for low harmonic distortion of input current THDi and for the single input power factor (see Master HP chapter); products with 12-pulse thyristor rectifiers in the same power range are available upon request. From 600 to 800kVA, the solutions are offered are equipped with a 12-pulse rectifier with and without a filter to reduce harmonics (optional)

Easy source

Master MPS makes powering UPS devices by power generators and MV/LV transformers easier and more efficient, reducing loss in systems and coils and correcting the power factor and eliminating harmonics by the loads powered by the UPS itself.

In addition to this, the progressive start-up of the rectifier and the possibility of reducing the recharge current of the batteries, allow for the containment of the input current absorbed and therefore do not overload the source, especially when the source is a generator.

Power continuity

For years, Riello UPS has been developing and offering various solutions for dealing with the different requirements and the problems that inevitably arise in the most critical applications. Riello UPS offers flexible, high-availability solutions that are able to adapt to the different system structures and different criticality levels.

Riello UPS creates UPS systems can tolerate a number of component or subsystem failures, while continuing to operate normally and to provide service without interruption.

This is achieved by installing carefully designed redundant elements, eliminating the common failure nodes, scheduling maintenance activities and through the control and supervision of the operating parameters of the system and the environment. The TEC service staff is ready to provide guidance and advice on projects.

Flexibility

Master Plus is suited to all types of applications, from computers to the most demanding industrial environments. Thanks to the broad range of accessories

and options, complex architectures and configurations can be created to ensure maximum power to critical loads: expansions (in redundancy or power) may be made in already-operating parallel systems, even without having to switch off any UPS that are already operating and thus, maintaining power to utilities. UGS and PSJ devices also ensure redundancy in the downstream distribution of the parallel system, creating a "selective" system that provides power to other connected utilities even when there are failures on one utility.

Battery care system: maximum battery care

Normally the batteries are kept charged by the rectifier; when mains power fails, the UPS uses this energy source to power its utilities. Therefore, proper battery care is critical to ensuring correct UPS operation in emergency conditions. Battery Care System consists of a series of features and capabilities that allow for battery management in order to obtain the best performance possible and extend their operating life.

- Dual level charging regime to optimise recharge currents and reduce charge times
- Temperature compensation and deep discharge protection to reduce overall battery ageing
- Charge blocking system to reduce electrolyte consumption and lengthen the life of VRLA batteries
- Battery tests to diagnose, in advance, any reduction in performance or problems with the batteries.

Master Plus is also compatible with different battery technologies: vented open lead acid, VRLA AGM and NiCd.

Ease of Installation

Master MPS requires only a very small space for installation (only 0.64 sqm for a 200KVA system); in addition, front access allows servicing of all major components from the front panel, making side access unnecessary. Given the upwards ventilation, Master Plus can be placed up against a wall, reducing the space to be left free, necessary in event the flow of hot air coming out the rear.

Specific solutions

The UPS can be adapted to meet your requirements. Contact TEC to discuss the feasibility of specific solutions and options not listed in the catalogue.

Advanced communication

- Compatible with Teleguard for teleassistance.
- Advanced communication, multi-platform, for all operating systems and network environments: Supervision and shutdown PowerShield³ software for Windows operating systems 7, 2008, Vista, 2003, XP, Linux, Mac OS X, Sun Solaris, Linux, Novell and other Unix operating systems.
- UPS is supplied with a cable for direct PC connection (Plug and PLayer)
- RS232 double serial port
- Slot for network adapter installation; ESD contact (Emergency Switching Device) for switching off the UPS by remote emergency button.
- Remote led mimic panel or graphic display.

Maximum reliability and availability

Distributed or centralised parallel up to 8 units per redundant (N+1) or powerparallel. A parallel between models with different power levels is possible. Hot System Expansion (HSE): HSE allows the insertion of a new UPS within an existing system, without the need to switch off the UPSs which are already operating or switch them to bypass mode. This guarantees maximum load protection, even during maintenance and enlargement.

Maximum levels of availability also in the event of an interruption to the parallel bus cable: the system is "FAULT TOLERANT". It is not affected by connection cable faults and continues powering the load without a continuity solution, signalling the anomaly with an alarm.

Efficiency Control System (ECS): is a system that optimises the efficiency of parallel systems, according to the power required by the load in that moment. However, N +1 redundancy is guaranteed, but every UPS working in parallel operates at the best load level possible in order to achieve the highest overall output.

OPTIONS

- UGS - UPS Group Synchroniser Allows 2 or more non-parallel UPS devices to remain synchronised even during mains power failure. The UGS also enables a Riello UPS to be synchronised with another power source that is independent and of a different power rating.
- PSJ - Parallel Systems Joiner Connects two UPS groups in parallel, hot (without output discontinuity) through a power coupling switch. A UPS group (slave) is permanently synchronised to the Master group both

when the mains supply is present or not present (thanks to the UGS synchronising device) .
 If there is a failure on one of the UPS devices in parallel, it is cut-off. The PSJ will automatically connect the remaining UPS to the other group in parallel via an external bypass, in order to ensure the redundancy of the load.

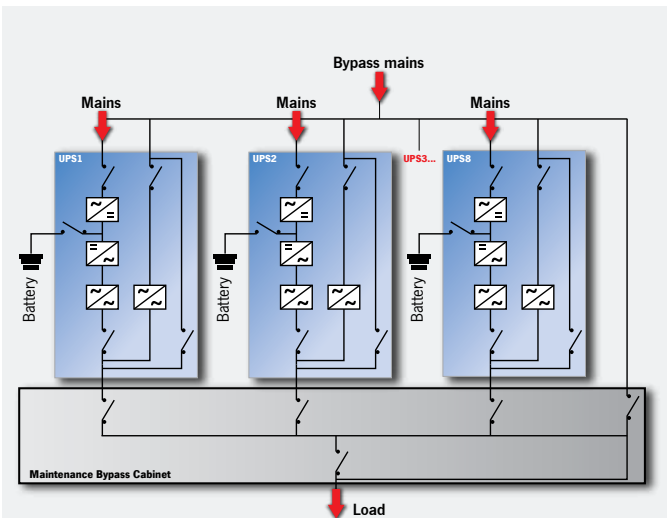

Parallel configuration of up to 8 units with distributed bypass
 Parallel architecture that ensures the redundancy of the power source. **+Flexibility and modularity**

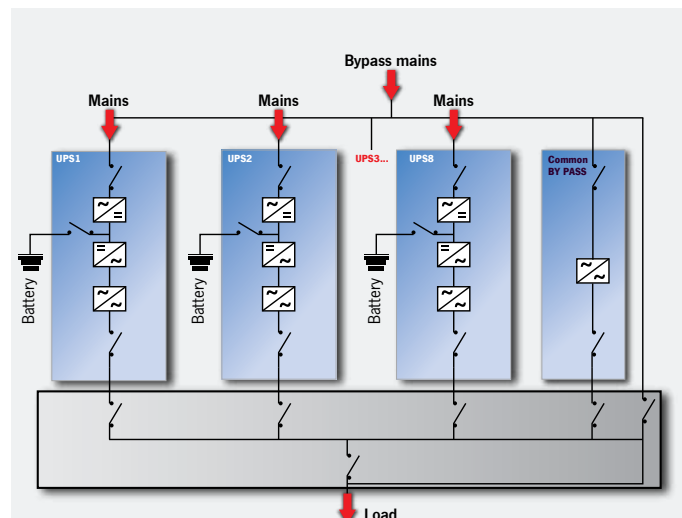

Parallel configuration of up to 8 units with common bypass
 Parallel architecture that ensures the redundancy of the power source, with autonomous bypass management. **+ Selectivity of downstream faults in bypass mode**

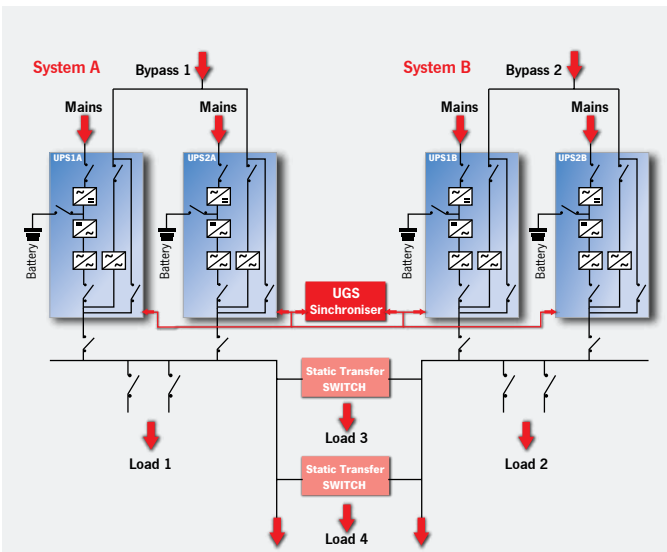

Dynamic dual bus configuration
 Solution that ensures redundancy until the distribution of the powersupply to the loads **+ Downstream fault discrimination**

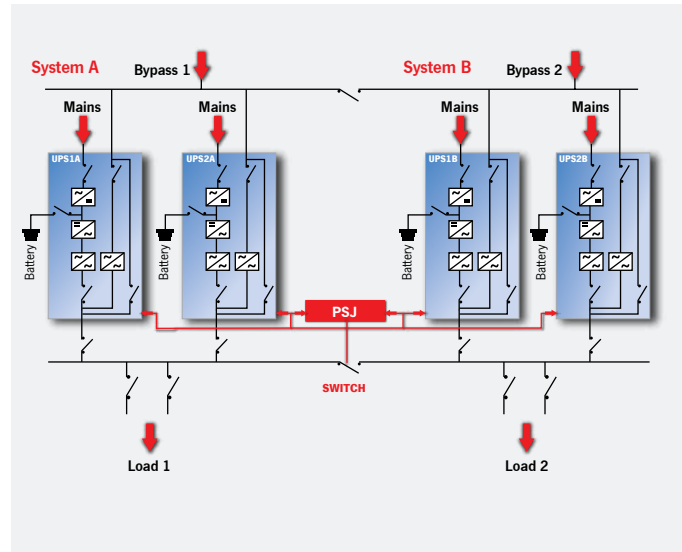

Dual bus system configuration
 Solution that ensures the redundancy of the power supply evenduring maintenance **+ High availability and redundancy**

dimensions (mm)

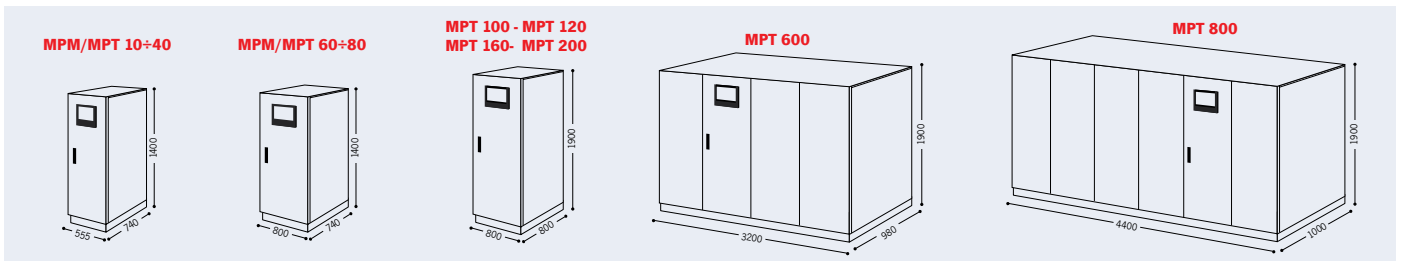

battery box

MODELS	BB 1900 396-L6 / BB 1900 396-L7 BB 1900 396-L8 / BB 1900 396-L9	BB 1900 480-L6 / BB 1900 480-L7 BB 1900 480-L8 / BB 1900 480-L9	BB 1400 384-B1	BB 1400 384-B2 / BB 1400 384-B3 BB 1400 384-B4 / BB 1400 384-B5
MODELS UPS	MPT 100-200 MPM 100	MPT 600-800 MHT 100-500	MPT 10-60	MPT 10-80
Dimensions (mm)				

MODELS	TCE 270	TCE 400	TLE 400
MODELS UPS	MPT 100-200 / MPM 100	MHT 100-250	MPT D 600-800 / MHT 300-500
Dimensions (mm)			

isolation transformers

MODELS	TI 10 T / TI 15 T / TI 20 T TI 30 T / TI 40 T	TI 60 T / TI 80 T	TI 100 T / TI 120 T TI 160 T	TI 200 T / TI 250 T	TI 300 T / TI 400 T TI 500 T / TI 600 T
Dimensions (mm)					

OPTIONS

- Isolation transformer
- Synchronisation device (see UGS)
- Hot connection device (see PSJ)
- Interface for generator
- Closed Loop parallel kit option
(Closed loop: to be ordered with the UPS)
- Empty battery cabinets or for prolonged runtimes

MODELS	MPM 10 *	MPM 15 *	MPM 20 *	MPM 30	MPM 40	MPM 60	MPM 80	MPM 100	
POWER	10	15	20	30	40	60	80	100	
INPUT									
Nominal voltage	380 - 400 - 415 Vac Three-phase								
Voltage tolerance	400 V + 20% /- 25%								
Frequency	45 - 65 Hz								
Soft start	0 ÷ 100% in 30" (selectable)								
Permissible frequency tolerance	± 2% (selectable from ± 1% to ± 5% from front panel)								
Standard equipment provided standard	Back Feed protection; separable bypass line								
BATTERIES									
Type	open lead acid and VRLA AGM / GEL; NiCd.								
Residual ripple voltage	< 1%								
Temperature compensation	-0.5 Vx°C								
Typical charge current	0.2 x C10								
OUTPUT									
Nominal power (kVA)	10	15	20	30	40	60	80	100	
Active power (kW)	9	13,5	18	27	36	54	72	90	
Number of phases	1								
Nominal voltage	220 - 230 - 240 Vac Single-phase								
Static stability	± 1%								
Dynamic stability	± 5% in 10 ms								
Voltage distortion	< 1% with linear load / < 3% with non-linear load								
Crest factor (I _{peak} /I _{rms})	3:1								
Frequency stability on battery	0.05%								
Frequency	50 or 60 Hz (selectable)								
Overload	110% for 60'; 125% for 10'; 150% for 1'								
INFO FOR INSTALLATION									
Net weight	200	220	230	290	340	440	520	650	
Dimensions (hwd) (mm)	1400 x 555 x 740					1400 x 800 x 740		1900 x 800 x 800	
Remote signals	voltage-free contacts								
Remote controls	ESD and bypass								
Communication	Double RS232 + remote contacts + 2 slots for communications interface								
Ambient temperature	0°C / +40°C								
Relative humidity	< 95% non-condensing								
Colour	Dark grey RAL 7016								
Noise level at 1 m (dBA)	54		62			62		63	
Protection level	IP20								
Smart Active Output	up to 98%								
Regulations	Regulatory Directives LV 2006/95/EC - 2004/108/EC; IEC Safety EN 62040-1; EMC IEC EN 62040-2; IEC Performance EN 62040-3								
Classification according to IEC 62040-3	(Voltage Frequency Independent) VFI - SS - 111								

* Also available with internal batteries

MODELS	MPT 10 *	MPT 15 *	MPT 20 *	MPT 30	MPT 40	MPT 60	MPT 80
POWER	10	15	20	30	40	60	80
INPUT							
Nominal voltage	380 - 400 - 415 Vac Three-phase						
Voltage tolerance	400 V + 20% /- 25%						
Frequency	45 ÷ 65 Hz						
Soft start	0 ÷ 100% in 30" (selectable)						
Permissible frequency tolerance	± 2% (selectable from ± 1% to ± 5% from front panel)						
Standard equipment provided standard	Back Feed protection; separable bypass line						
BATTERIES							
Type	open lead acid and VRLA AGM / GEL; NiCd.						
Residual ripple voltage	< 1%						
Temperature compensation	-0.5 Vx°C						
Typical charge current	0.2 x C10						
OUTPUT							
Nominal power (kVA)	10	15	20	30	40	60	80
Active power (kW)	9	13,5	18	27	36	54	72
Number of phases	3 + N						
Nominal voltage	380 - 400 - 415 Vac Three-phase + N						
Static stability	± 1%						
Dynamic stability	± 5% in 10 ms						
Voltage distortion	< 1% with linear load / < 3% with non-linear load						
Crest factor (Ipeak/Irms)	3:1						
Frequency stability on battery	0.05%						
Frequency	50 or 60 Hz (selectable)						
Overload	110% for 60'; 125% for 10'; 150% for 1'						
INFO FOR INSTALLATION							
Weight without internal batteries (kg)	212	220	230	280	330	450	600
Dimensions (hwd) (mm)	1400 x 555 x 740					1400 x 800 x 740	
Remote signals	voltage-free contacts						
Remote controls	ESD and bypass						
Communication	Double RS232 + remote contacts + 2 slots for communications interface						
Ambient temperature	0°C / +40°C						
Relative humidity	< 95% non-condensing						
Colour	Dark grey RAL 7016						
Noise level at 1 m (dBA)	54		60			62	
Protection level	IP20						
Smart Active Output	up to 98%						
Regulations	Regulatory Directives LV 2006/95/EC - 2004/108/EC; IEC Safety EN 62040-1; EMC IEC EN 62040-2; IEC Performance EN 62040-3						
Classification according to IEC 62040-3	(Voltage Frequency Independent) VFI - SS - 111						

* Also available with internal batteries

MODELS	MPT 100	MPT 120	MPT 160	MPT 200
POWER	100	120	160	200
INPUT				
Nominal voltage	380 - 400 - 415 Vac Three-phase			
Voltage tolerance	400 V + 20% /- 25%			
Frequency	45 ÷ 65 Hz			
Soft start	0 ÷ 100% in 30" (selectable)			
Permissible frequency tolerance	± 2% (selectable from ± 1% to ± 5% from front panel)			
Standard equipment provided standard	Back Feed protection; separable bypass line			
BATTERIES				
Type	open lead acid and VRLA AGM / GEL; NiCd.			
Residual ripple voltage	< 1%			
Temperature compensation	-0.5 Vx°C			
Typical charge current	0.2 x C10			
OUTPUT				
Nominal power (kVA)	100	120	160	200
Active power (kW)	90	96	144	180
Number of phases	3 + N			
Nominal voltage	380 - 400 - 415 Vac Three-phase + N			
Static stability	± 1%			
Dynamic stability	± 5% in 10 ms			
Voltage distortion	< 1% with linear load / < 3% with non-linear load			
Crest factor (I _{peak} /I _{rms})	3:1			
Frequency stability on battery	0.05%			
Frequency	50 or 60 Hz (selectable)			
Overload	110% for 60'; 125% for 10'; 150% for 1'			
INFO FOR INSTALLATION				
Weight (kg)	640	650	770	810
Dimensions (hwd) (mm)	1900 x 800 x 800			
Remote signals	voltage-free contacts			
Remote controls	ESD and bypass			
Communication	Double RS232 + remote contacts + 2 slots for communications interface			
Ambient temperature	0°C / +40°C			
Relative humidity	< 95% non-condensing			
Colour	Dark grey RAL 7016			
Noise level at 1 m (dBA)	63 ÷ 68			
Protection level	IP20			
Smart Active Output	up to 98%			
Regulations	Regulatory Directives LV 2006/95/EC - 2004/108/EC; IEC Safety EN 62040-1; EMC IEC EN 62040-2; IEC Performance EN 62040-3			
Classification according to IEC 62040-3	(Voltage Frequency Independent) VFI - SS - 111			

MODELS	MPT 600	MPT 800
POWER	600	800
INPUT		
Nominal voltage	380 - 400 - 415 Vac Three-phase	
Voltage tolerance	400 V \pm 20%	
Frequency	45 \div 65 Hz	
Power factor	> 0.93 in HC version	
Current distortion	< 3% in HC version	
Soft start	0 \div 100% in 30" (selectable)	
Permissible frequency tolerance	\pm 2% (selectable from \pm 1% to \pm 5% from front panel)	
Standard equipment provided standard	Back Feed protection; separable bypass line	
BATTERIES		
Type	open lead acid and VRLA AGM / GEL; NiCd.	
Residual ripple voltage	< 1%	
Temperature compensation	-0.5 Vx°C	
Typical charge current	0.2 x C10	
OUTPUT		
Nominal power (kVA)	600	800
Active power (kW)	480	640
Number of phases	3 + N	
Nominal voltage	380 - 400 - 415 Vac Three-phase + N	
Static stability	\pm 1%	
Dynamic stability	\pm 5% in 10 ms	
Voltage distortion	< 1% with linear load / < 3% with non-linear load	
Crest factor (Ipeak/Irms)	3:1	
Frequency stability on battery	0.05%	
Frequency	50 or 60 Hz (selectable)	
Overload	110% for 60'; 125% for 10'; 150% for 1'	
INFO FOR INSTALLATION		
Weight (kg)	4000	5300
Dimensions (hwd) (mm)	1900 x 3200 x 1000	1900 x 4400 x 1000
Remote signals	voltage-free contacts	
Remote controls	ESD and bypass	
Communication	Double RS232 + remote contacts + 2 slots for communications interface	
Ambient temperature	0°C / +40°C	
Relative humidity	< 95% non-condensing	
Colour	Dark grey RAL 7016	
Noise level at 1 m (dBA)	< 75	< 78
Protection level	IP20	
Smart Active Output	up to 98%	
Regulations	Regulatory Directives LV 2006/95/EC - 2004/108/EC; IEC Safety EN 62040-1; EMC IEC EN 62040-2; IEC Performance EN 62040-3	
Classification according to IEC 62040-3	(Voltage Frequency Independent) VFI - SS - 111	